

VS

3 STATION



Spreader Feeder



VS-3 Extra High Quality, Three Station, Large Piece Spreader Feeder

Each of the three feeding stations has 2 individual clamps. After inserting 2 corners of the piece into the clamps, the VS-3 spreads, centers and lays the front edge of the piece onto the belts leading to the ironer.

A fast rotating roll whips the trailing edge into a vacuum box while brushes moving laterally from the center spread the piece. Another set of brushes on top and underneath the piece, move laterally from the center to smooth out the edges. A sandwich conveyor briefly holds the back of the piece so that the leading edge can be stretched by the ironer feed table. These three features result in unsurpassed feeding quality at high production rates.

With the touch of a button, the feeding head moves forward so small pieces can be fed directly onto the conveyor leading to the ironer. The PLC touch screen control stores up to 100 programs so that the ideal conditions can be created for each type of material processed.

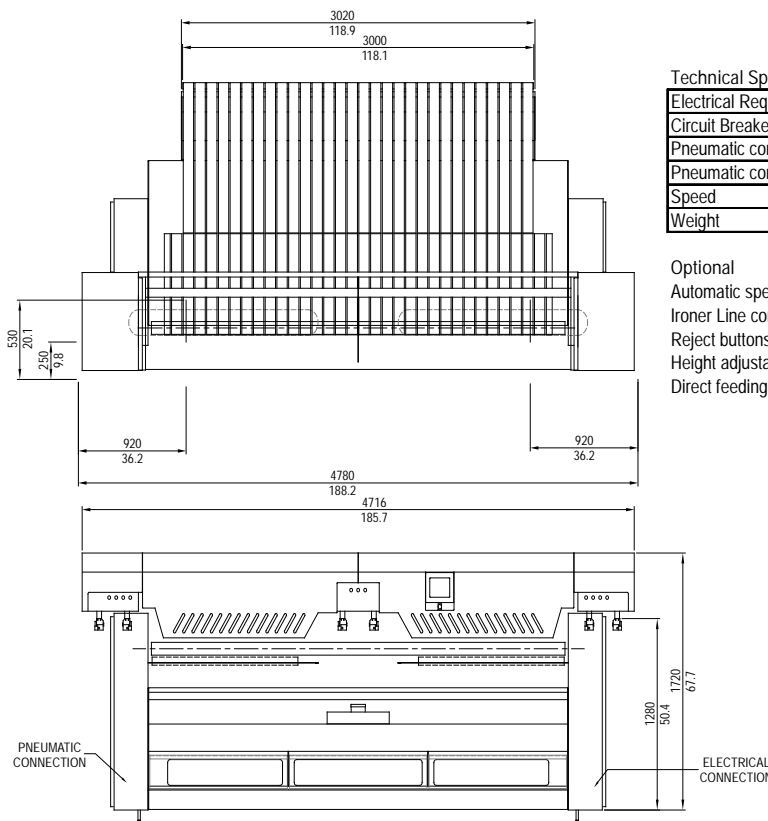

Technical Specifications

Electrical Requirements	208-230V, 3PH	440-460V, 3PH
Circuit Breaker	20A	10A
Pneumatic connections	13mm	1/2in
Pneumatic consumption	18 liters/pc	4.8 gal/pc
Speed	8-45 m/min	26-148 ft/min
Weight	2700 kg	5940 lbs

Optional

- Automatic speed synchronization with the ironer
- Ironer Line control that adjusts the speed of the entire ironing operation
- Reject buttons on each station
- Height adjustable feeding clamps
- Direct feeding into the first ironer chest

